

6 | 5 | 4 | 3 | 2 | 1

D

D

C

C

B

B

A

A

TECHNICAL SPECIFICATIONS	
Power Supply	230v / 415v
Motor Rating	250W
Frequency	50Hz
Revolutions per min.	3000
Max. Vertical Output	10m
Max. Horizontal Output	200m
Max. Flow Rate	4500 Litres/Min
Max. Liquid Temperature	40 Deg. C
Discharge Size	63 O.D. MDPE
Cable Length	10m

ACCESS COVER (CLEAR OPENINGS)	
DIAMETER (mm)	TYPE
450	Pedestrian

FABRICATION SPECIFICATIONS				
ITEM	INDEX	DEPTH (mm)	DIAMETER (mm)	CLOCKFACE POSITION
Tank Depth	A	1000		
Tank Dia.	B		610	
Inlet	C1	250	110	
Inlet	C2			
Inlet	C3			
Discharge	D	200	63	12
Cable Duct			40	
Vent				

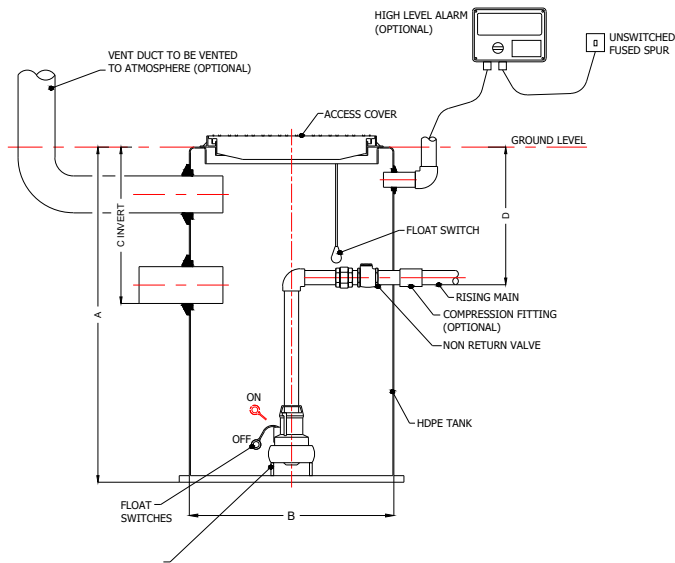
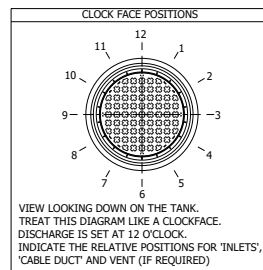

PUMP c/w INTEGRAL FLOAT
2" SOLID HANDLING WITH 10m (10VX) HEAD
PUMPS WITH MACERATOR PUMP (MC) OPTIONS

COMMENTS
PLEASE NOTE THE INLET CAN BE SUPPLIED LOOSE AND DRILLED ON SITE

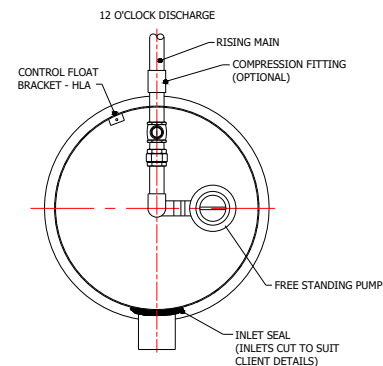

DRAWN BY Jc	DRAWING DATE (DD/MM/YY) 04/03/21	EFFECTIVE DATE: (DD/MM/YY) 04/03/21	PRODUCT NAME: Tricel Micro 300L Single	PRODUCT NUMBER: 104368	ACC NUMBER:	
TOLERANCE: +/- 5		MATERIAL: MDPE	SCALE: NOT TO SCALE	DRAWING TYPE: FG		
UNITS: mm		DRWG NO: N/A	TANK REVISION: 0	REV. NO. 0	PAGE SIZE: A4	
JOB NUMBER: N/A		WEIGHT (KG): 40kg	PROJECT NO:	ECO NO:	COUNTRY: UK	

6 | 5 | 4 | 3 | 2 | 1