

UK*

* INCLUDING NORTHERN IRELAND



WASTEWATER TREATMENT

Tricel® Maxus

Treatment Systems for 50+ Population Equivalent

Innovative design for superior performance



What is Tricel Maxus

Tricel Maxus wastewater treatment plants are designed to treat wastewater arising from human activity in applications greater than 50PE. Applications includes housing estates, hotels, restaurants, campsites, factories or retail units to name a few. These highly versatile systems are individually sized to suit every possible scenario over 50PE.

The Tricel Maxus operates on Submerged Aerated Filter (SAF) technology. The plant is controlled by the E-III control panel through which all electrical components are connected. They are robust and easy to install with multiple configurations possible to suit any site. Simple in operation, they are easy to maintain over the lifespan of the product.

How does it work

Tricel Maxus utilises highly effective SAF technology treating wastewater in 4 stages:

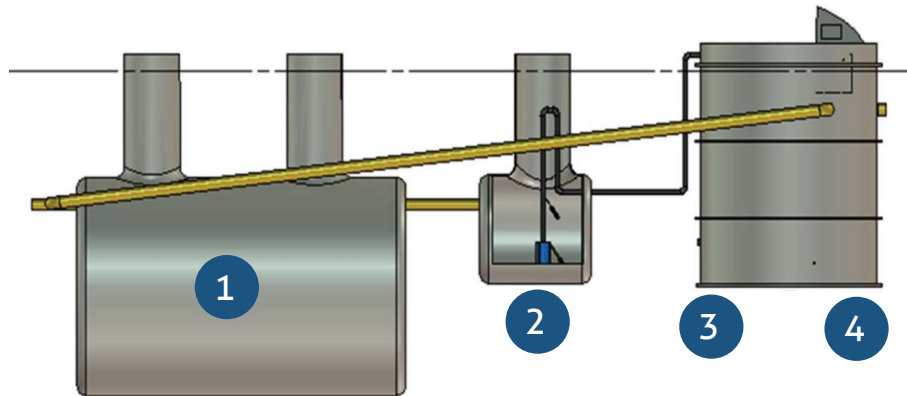

1. Wastewater enters into the Tricel Maxus system in **the settlement tank**. Here primary treatment occurs. Heavy solids are separated out of the wastewater and settle to form a sludge on the base of the tank. Lighter solids, such as oils, fats or grease, float to top of the wastewater and are retained within the settlement tank.
2. From here the partially treated wastewater enters **the buffer tank**. The buffer tank will even out any fluctuations for the incoming water load. Pumps located at the bottom of the buffer tank feed the wastewater forward into the treatment plant.
3. In **the biological treatment zone**, the submerged aerated filter, with a large surface area for the microbes, is exposed to aeration as the wastewater passes through. The control panel adjusts the aeration to match the incoming flow to ensure extremely efficient operation. The system will never clog and does not need any maintenance or chemicals.
4. In **the clarifier**, bio sludge from the treatment process settles out of the treated liquid. Airlift pumps recirculate the bio sludge from the base of the tank back to the settlement tank. The fully treated liquid is now ready to discharge from the plant.

Key features & benefits

- ▶ **Excellent treatment** from proven SAF technology.
- ▶ **Ideal for seasonal loads of constant loads.** The control panel will automatically adjust to the incoming load to ensure optimum performance.
- ▶ **Extensively tested and ETA verified for holiday home applications.** System will go into power saving mode during periods of no flow and restart once flow is detected without the need for any manual inputs.
- ▶ **Swift back up and service located in the UK.** Range of service contracts available.
- ▶ **Full design engineered solutions offered.** Bespoke solutions offered for every unique site to ensure best performance. **GRP or Concrete settlement tank options.**
- ▶ **Flexible installation options to suit any site.** This can fit plants into difficult sites or simply save space.
- ▶ Versatile technology which **can adapt to different loadings or effluent strengths.**
- ▶ Simple operation using long life reliable components leading to **low running costs.** No moving parts within the plant making it easy to maintain.

Call us today for a **Free Quote** or details of your local partner

+44 (0) 1934 422 311
environment@tricel.co.uk

Installations



▶ Installation with combined GRP settlement and buffer tanks.



▶ Treatment plant during installation.



▶ Remote settlement and buffer tanks to suit a site with restricted space.



▶ Installation with combined GRP settlement and buffer tanks.



▶ Treatment plant during installation.



▶ Finished installation.

Technical characteristics/ Plant dimensions

Code	PE	Settlement And Buffer Tank*				Treatment Plant			
		Tank	L (M)	W (M)	H (M)	Plant Shape**	L (M)	W (M)	H (M)
66M5000	66	Settlement	6.60	1.64	2.05	Circular	2.00	2.00	2.20
		Buffer	1.60	1.64	2.05				
88M6000	88	Settlement	6.60	1.64	2.05	Circular	2.30	2.30	2.20
		Buffer	3.60	1.64	2.05				
112J25	112	Settlement	6.60	1.64	2.05	Rectangular	2.80	2.16	2.22
		Buffer	6.60	1.64	2.05				
154J50	154	Combined	5.70	2.87	2.70	Rectangular	3.30	2.16	2.22
175J75	175	Combined	6.17	2.87	2.70	Rectangular	3.95	2.16	2.22
238J100	238	Combined	9.05	2.87	2.70	Rectangular	5.45	2.16	2.22
294J50X2	294	Combined	10.89	2.87	2.70	Rectangular	6.60	2.16	2.22
385J75X2	385	Combined	14.12	2.87	2.70	Rectangular	7.90	2.16	2.22
560J100X2	560	Settlement	9.95	2.87	2.70	Rectangular	10.90	2.16	2.22
		Buffer	9.95	2.87	2.70				

*All settlement and buffer tank dimensions are for GRP tanks as standard. Concrete options are available.

** Please note, the treatment plant is circular for up to 88PE and rectangular for plants over 88PE.

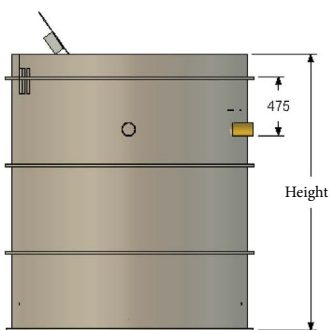

Profile view of circular shape

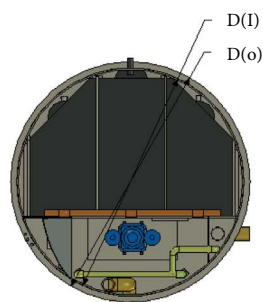

Top view of circular shape

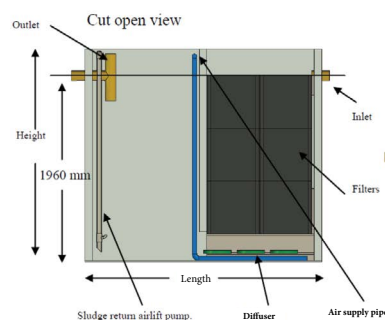

Profile view of rectangular shape

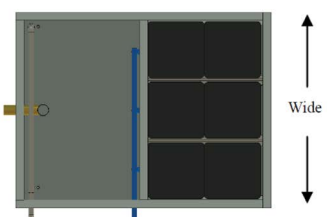

Top view of rectangular shape

Tricel Group

Tricel is a world recognised global provider of **high-performance solutions**. Today, the company operates across multiple industries such as **Environmental, Construction, Water and Distribution**, including both composite materials and lubricants.

We occupy a unique position in the field of reinforced plastics, combining the technical expertise of **over 60 years in the press-moulding and composites industry**. Tricel is proud of being one of the largest manufacturers of wastewater treatment plants in Europe, and are regarded by regulators as the standard setters within the industry.

Our company offers industry **leading innovative solutions** that our customers can trust, and with operations in 12 locations across Europe we supply a comprehensive range of products to **over 50 countries worldwide**.

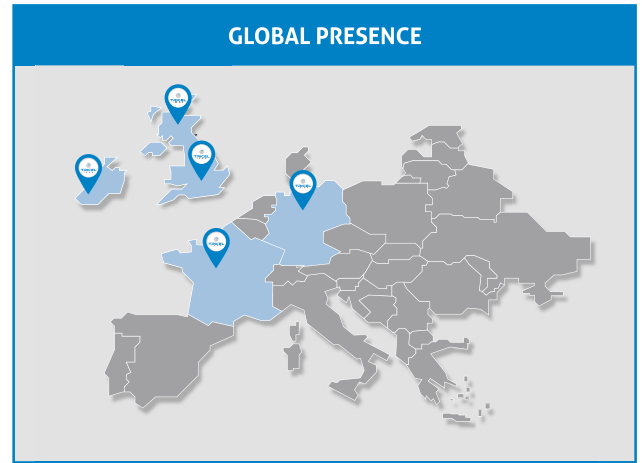

Membership of governing bodies on wastewater treatment



British Water is the leading association representing suppliers, manufacturers, contractors, consultants and others in the UK water industry supply chain.

Our Full Range of Tricel® Wastewater Treatment Solutions



Tricel® Novo
Wastewater Treatment Plant



Tricel® Vento
Septic Tank



Tricel® Puraflo
Packaged Filter System



Tricel® Supra
Wastewater Treatment Plant



Tricel® Vitae
Wastewater Treatment Plant

Call us today for a **Free Quote** or details of your local partner
+44 (0) 1934 422 311
environment@tricel.co.uk

Tricel Environmental UK, A trading brand of Dewey Waters Ltd., Tricel Weston, Winterstoke Road, Weston-super-Mare, BS24 9AN, United Kingdom.

Tel: +44 (0) 1934 422 311 | Email: environment@tricel.co.uk | www.tricel.co.uk

In accordance with Tricel's normal policy of product development these specifications are subject to change without notice.

